

Features		Applications				
<ul style="list-style-type: none"> ● Ultra Stable ● Wide Temperature Range ● Fast Warming-up 		<ul style="list-style-type: none"> ● Base Stations ● Instrumentations ● Synthesizer ● Medical Electronics 				
						
BO2525L Specifications						
Parameter	Value			Unit	Condition	
	Min.	Typ.	Max.			
Supply Voltage	-	5.0	-	V	V _{cc} ±5%	
	-	12.0	-	V	V _{cc} ±5%	
Power Consumption	-	-	3.0	W		
	-	-	1.0	W		
Frequency Range	10 ~ 40			MHz		
Nominal Frequency	10, 20, 40			MHz		
Initial Frequency Tolerance	-	-	±100	ppb	At shipment, nominal EFC	
Freq. Stability Vs. Temp.	±3	-	±10	ppb	-20°C ~ +70°C	
	±5	-	±10	ppb	-40°C ~ +70°C	
	±10	-	±50	ppb	-40°C ~ +85°C	
	-	-	±100	ppb	-55°C ~ +85°C	
Sine Wave	Output Level	7	-	-	dBm	
	Harmonics	-	-	-40	dBc	
	Spurious	-	-	-80	dBc	
	Load	-	50	-	Ω	
HCMOS	V _{OH}	2.4	-	-	V	HCMOS Output, Load=15pf
	V _{OL}	-	-	0.4	V	HCMOS Output, Load=15pf
	Duty Cycle	45	-	55	%	(V _{OH} - V _{OL})/2
	Rise/Fall edge	-	-	6	ns	HCMOS Output, Load=15pf
	Load	-	15	-	pf	
Short-term Stability@10MHz	-	-	3×10 ⁻¹²		Test after 15 Min.	
Warm-up Time	-	-	5	Min	At +25°C, with tolerance ±100ppb	
Supply Sensitivity	-	-	±5	ppb	V _{cc} ±5%	
Load Sensitivity	-	-	±5		Load±5%	
Aging per Day	-	-	±0.5		After 30 days of operation	
Aging per Year	-	-	±50		After 30 days of operation	
SSB Phase Noise @10MHz	-	-	-120	dBc/Hz	Offset 10Hz	@+25°C
	-	-	-140		Offset 100Hz	
	-	-	-160		Offset 1kHz	
	-	-	-165		Offset 10kHz	
	-	-	-168		Offset 100kHz	
Control Voltage Range	0	-	5	V		
Frequency Tuning Range	±0.5	-	±2.0	ppm		
Tuning Slope	Positive					
Environmental Conditions						
Operating Temperature Range	-55°C ~ +85°C					
Storage Temperature Range	-55°C ~ +125°C					

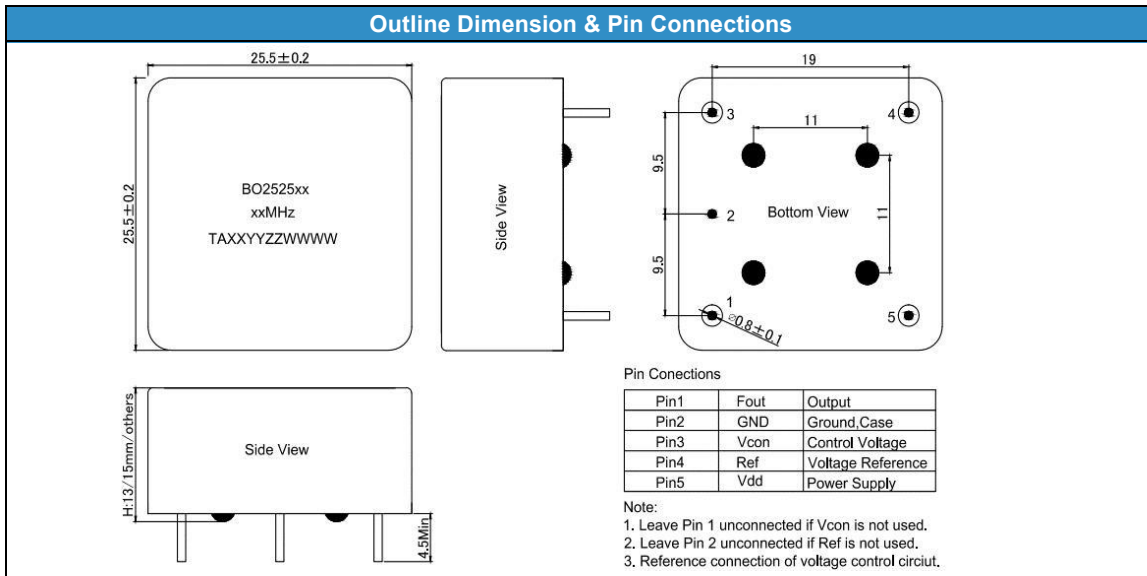

Reliability	
Parameter	Condition
Temperature Stress Test	IEC60068, GJB360B
Mechanical Stress Test	IEC60068, GJB360B
EMC Test (ESD)	IEC61000, JESD22
Solderability	EIA/JESD22-B102-C
RoHS	RoHS Directive 2011/65/EU Annex II Recasting 2002/95/EC

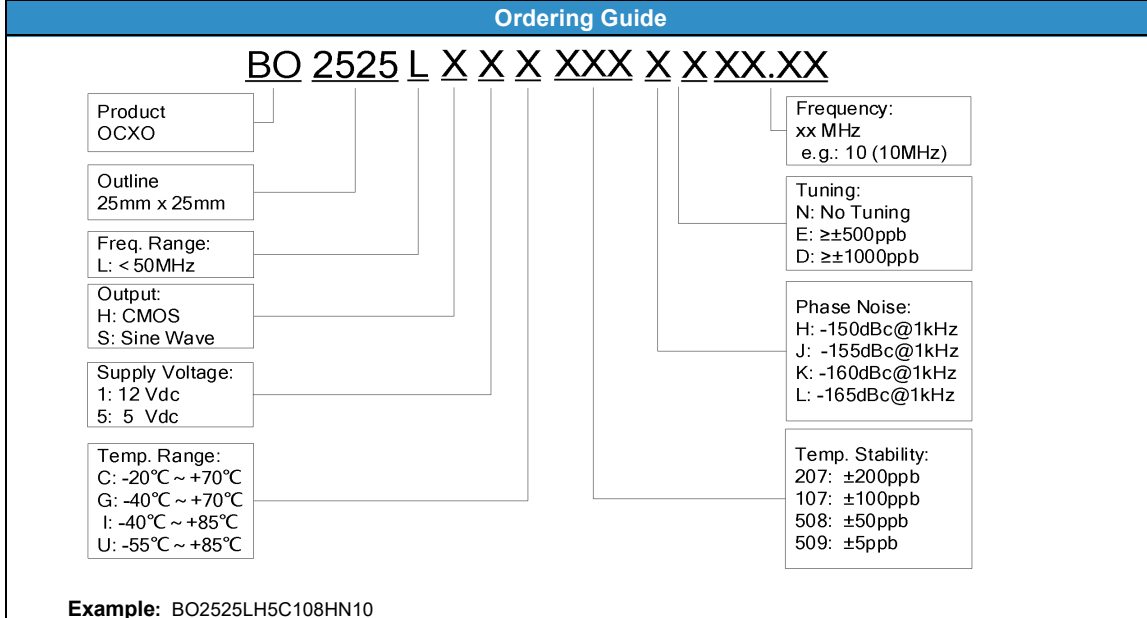

Disclaimer
 Xtaltq Technologies Co., Limited reserves the right to make changes to the product(s) and/or information contained herein without notice. No liability is assumed as a result of their use or application. No rights under any patent accompany the sale of any such product(s) or information.